

SAVE THESE INSTRUCTIONS



5252 East 36th Street North
Wichita, KS USA 67220-3205
TEL: 316-686-7361
FAX: 316-686-6746

GREAT PLAINS INDUSTRIES, INC.

"A Great Plains Ventures Subsidiary"

www.gpi.net

1-800-835-0113

**Use this manual with:
Heavy Duty Fuel Pumps**

M-3025 12-Volt DC & M-3425 24-Volt DC

- MODELS: M-3025-AL (Automatic Nozzle)
M-3025-ML (Manual Nozzle)
M-3425-AL (Automatic Nozzle)
M-3425-ML (Manual Nozzle)

Contractor Special Fuel Pumps

M-3025CS 12-Volt DC & M-3425CS 24-Volt DC

- MODELS: M-3025CS-A (Automatic Nozzle)
M-3025CS-PO
M-3425CS-A (Automatic Nozzle)
M-3425CS-PO

STOP

**DO NOT RETURN
THIS PRODUCT
TO THE STORE!**

Please contact GPI before returning any product. If you are missing parts or experience problems with your installation, our Customer Support Department will be happy to assist you.

GPI Customer Support
800-835-0113 or
316-686-7361

**M-3025
Models**



**M-3025CS
Models**

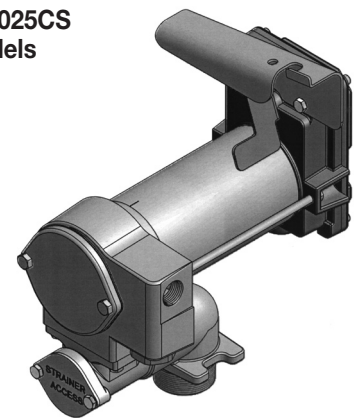

TABLE OF CONTENTS

General Information.....2
Safety Instructions.....2
Installation3
Operation.....4
Maintenance.....4
Repair5
Troubleshooting.....5
Specifications.....7
Illustrated Parts Drawing.....8
Parts and Service.....9

To the owner...

Congratulations on receiving your GPI fuel pump. We are pleased to provide you with a system designed to give you maximum reliability and efficiency.

Your fuel pump is designed, tested, and approved for use with gasoline blends, diesel fuel blends and kerosene. Please take all due precautions when handling these flammable liquids. Your safety is important to us.

Also, to assure the longest possible service life, it is important that you follow the operation and maintenance procedures outlined in this manual. We are proud to provide you with a quality product and dedicated support. Together with your conscientious use, we are sure that you will obtain years of safe, dependable service.

President
Great Plains Industries, Inc.



Great Plains Industries, Inc. is a member of the Petroleum Equipment Institute.

GENERAL INFORMATION

The purpose of this manual is to assist you in installing, operating and maintaining your GPI pump. This manual covers 12- and 24-volt DC models M-3025 and M-3425.

Models M-3025 and M-3025CS must be connected to a 12-volt DC power source only.

Models M-3425 and M-3425CS must be connected to a 24-volt power source only.

Do not attempt connection of any pump to a 115-volt AC or 230-volt AC power source.



An automatic bypass valve prevents pressure build up when the pump is on with the nozzle closed. To avoid damage, do not run the pump more than 10 minutes with the nozzle closed.

The duty cycle of this pump is 30 minutes ON and 30 minutes OFF. Allow the pump to cool for 30 minutes.

This pump is designed for use **only** with gasoline (up to 15% alcohol blends such as E-15), diesel fuel (up to 20% biodiesel blends such as B20) and kerosene. **Do not** use this pump for dispensing any fluids other than those for which it was designed. To do so may damage pump components and will void the warranty.

This pump is designed to operate on a typical DC automotive electrical system. The pump is designed to operate with the appropriate DC voltage at the motor leads and the ratings are determined at this voltage. Performance may vary due to length of power cord, battery condition or output from the vehicle charging system that will affect system voltage.

Do not leave the system running with fluids. "Dry running" can damage the pump.

Do not pump the tank completely dry, as contaminants from the bottom of the tank may enter the pump.

SAFETY INSTRUCTIONS



The following safety alert symbols are used in this manual.

DANGER

DANGER indicates a hazardous situation which, if not avoided, will result in death or serious injury.

WARNING

WARNING indicates a hazardous situation which, if not avoided, could result in death or serious injury.

CAUTION

CAUTION indicates a hazardous situation which, if not avoided, may result in minor or moderate injury.

It is your responsibility to:

- Know and follow applicable national, state and local safety codes pertaining to installing and operating electrical equipment for use with flammable liquids.
- Know and follow all safety precautions when handling petroleum fuels.
- Ensure that all equipment operators have access to adequate instructions concerning safe operating and maintenance procedures.

Observe all safety precautions concerning safe handling of petroleum fuels.

To ensure safe operation, all fuel transfer systems must be properly grounded. Proper grounding means a continuous metal-to-metal contact from one component to the next, including tank, bung, pump, meter, filter, hose and nozzle. Care should be taken to ensure proper grounding during initial installation and after any service or repair procedures. For your safety, please take a moment to review the warnings below.

To prevent physical injury, observe precautions against fire or explosion when dispensing fuel. Do not operate the system in the presence of any source of ignition including running or hot engines, lighted cigarettes, or gas or electric heaters.

Observe precautions against electrical shock when operating the system. Serious or fatal shock can result from operating electrical equipment in damp or wet locations.

Inspect external pump wiring regularly to make sure it is correctly attached to the battery. To avoid electrical shock, use extra care when connecting the pump to power.

Avoid prolonged skin contact with petroleum fuels. Use protective goggles, gloves and aprons in case of splashing or spills. Change saturated clothing and wash skin promptly with soap and water.

Observe precautions against electrical shock when servicing the pump. **Always** disconnect power before repairing or servicing. **Never** apply electrical power to the system when any of the coverplates are removed.

If using solvent to clean pump components or tank, observe the solvent manufacturer's recommendations for safe use and disposal.

INSTALLATION

Install Suction Pipe

Your pump is designed to mount directly to a standard 2-inch NPT tank fitting. For the suction pipe, a 1-inch galvanized steel pipe cut to length and threaded on one end may be used. Suction pipe should extend to within 3 inches of tank bottom. Apply thread tape to the suction pipe thread and securely tighten the suction pipe to the pump inlet port.

Make sure any check valve or foot valves used are equipped with proper pressure relief valves.

Install Pump on Tank

- Clean the tank interior of all dirt and foreign material.
- Place the pump with suction pipe installed on the tank fitting and tighten securely. Make sure the pump is not cross-threaded.
- To prevent pressure build-up and possible fuel leaks through the nozzle, make sure the tank is vented. A vent cap rated at 3 psi or less is recommended.

Install Electrical Connections

A grounding connection is provided. It is identified as a green colored binding head screw in the electrical cavity.

Models M-3025 and M-3025CS must be connected to a 12-volt DC power source only.

Models M-3425 and M-3425CS must be connected to a 24-volt power source only.

Do not attempt connection of any pump to a 115-volt AC or 230-volt AC power source

For installation in unclassified areas, the supplied power cord, fuse and strain relief grip may be used.

NOTE: These components have not been evaluated as part of the UL Listed Equipment and are not intended for use in a Hazardous (Classified) Location.

To install the power cord, remove the electrical coverplate. (Figure 1)

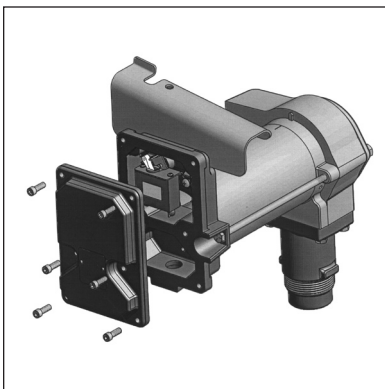

Figure 1

Slide the strain relief grip onto the power cord so that the threaded end of the strain relief grip faces the stripped power wires. (Figure 2)

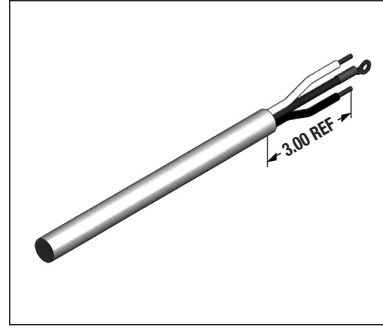

Figure 2

Insert the power cord through the 3/4 inch NPT connection on the bottom of the pump. Attach ground wire (green) using green ground screw located inside the electrical cavity. (Figure 3)

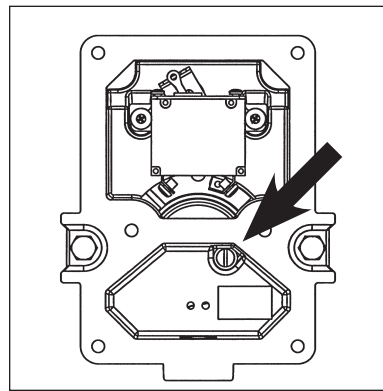

Figure 3

Using wire nuts, connect the black wire to the black wire and the white (or red) wire to the white (or red) wire in the pump's electrical cavity. Position the wires inside the electrical cavity and tighten the strain relief grip securely. Make sure surfaces are clean. Install the coverplate and tighten securely.

⚠ WARNING

Carefully route the power cord to the battery, protecting the power cord from hot surfaces, sharp edges or anything that could damage the power cord, resulting in a short circuit.

A fuse is provided to protect the power cord and motor. Install fuse in the white (or red) wire of the power cord as close as possible to the battery. Connect the red wire of the fuse to the positive (ungrounded) side of battery. Connect black wire to the negative (grounded) side of the battery.

Failure to follow these instruction could result in death, serious injury or loss of equipment due to short circuit, fire or explosion.

⚠ DANGER

If the pump is to be installed in a Hazardous (Classified) location, it must be installed by a licensed electrician and conform to National Fire Protection Association (NFPA) codes 30 and 70. You, as the owner, are responsible for seeing that the installation and operation of your pump complies with NFPA codes as well as any applicable state and local codes. Rigid conduit must be used to install wiring. Note that the lead wires are factory-sealed isolating the motor from the junction box.

Failure to follow these wiring instructions may result in death or serious injury from shock, fire or explosion.

Install Hose and Nozzle

All threaded fuel connections must be sealed with thread tape or a pipe thread sealing compound approved for use with petroleum fuels.

After sealing the threads, tighten the hose into the pump outlet and the nozzle on the hose. The nozzle can be placed in the nozzle holder only when the pump is off.

The nozzle holder allows the pump to be locked when the nozzle is in place.

OPERATION

ALWAYS FOLLOW SAFETY PRECAUTIONS WHEN OPERATING THIS EQUIPMENT. REVIEW THE SAFETY INSTRUCTIONS. Before each use, repair leaks around seals or connections. Make sure hoses are in good condition and connections are tight. Make sure the work area is dry. **MAKE SURE THE PUMP IS PROPERLY GROUNDED.** Repair any corroded or damaged wiring before use. Ensure the tank contains enough fuel. Make sure the fuel is not contaminated with debris.

Dispense Fuel

Turn the pump on by removing the nozzle from its holder and pushing down on the switch lever. Insert the nozzle into the receiving tank and squeeze the handle to start fuel flow. When done, release the nozzle handle.

After dispensing fuel, pull the front end of the switch lever up to turn the pump off and return the nozzle to the holder. The nozzle may be locked in place to prevent unauthorized use by installing a padlock (not provided) through the hole in the top of the nozzle cover.



The pump is designed to be self-priming. If fuel is not delivered within 15 to 20 seconds, turn the pump off and refer to the priming information in the Troubleshooting Section.

An automatic bypass valve prevents pressure buildup when the pump is on with the nozzle closed. To avoid pump damage, do not run the pump for more than 10 minutes with the nozzle closed.

Motor Protector

This pump is equipped with a motor protective device that also serves as the ON / OFF switch.

NOTE: The motor protective device is not intended to provide branch circuit protection.

- If motor is overloaded, the protective device trips and opens the circuit. This feature protects the motor from damage and must be reset manually.
- To reset, turn the switch lever off and then back on.
- If the protective device trips again quickly, turn the power off at the source before attempting to troubleshoot the problem. Follow instructions as described in the Troubleshooting Section of this manual.
- Make sure the switch lever is off before restoring power.
- Turn the switch lever on and restart.

MAINTENANCE

This pump is designed for minimum maintenance. Motor bearings are sealed and require no lubrication. Inspect the pump and components regularly for fuel leaks and make sure the hose and power cord are in good condition. Keep the pump exterior clean to help identify leaks.

Do not use this pump for water, chemicals or herbicides. Dispensing any fluid other than those listed in this manual will damage the pump. Use of the pump with unauthorized fluids will void the warranty.

To Clean or Replace Strainer

All pump models have an inlet strainer. If flowrate is reduced, clean or replace strainer (see below).

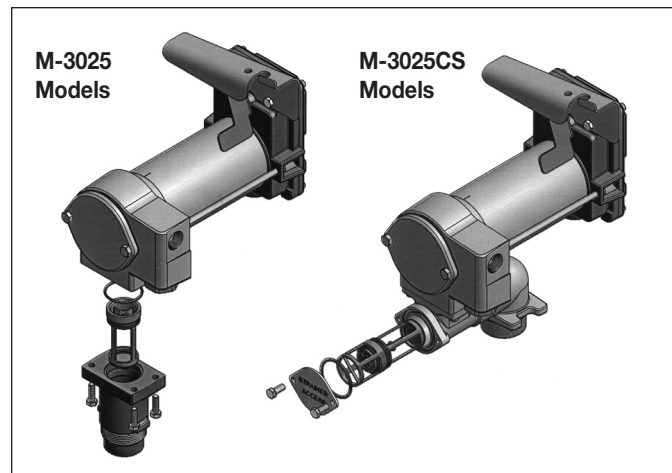

Turn the pump off and disconnect from power. Depending on the model, remove and clean the strainer with a soft-bristled brush and solvent. If the strainer is very dirty, compressed air may be used. If damaged, replace the strainer.

Replace components making sure that they are seated and fasteners are tightened securely.

REPAIR

Carefully inspect all parts for wear or damage. Replace components, as necessary. The Illustrated Parts List gives information on replacement parts and kits.

Review the Safety Instructions before proceeding.

⚠ WARNING

Observe precautions against electrical shock when servicing the pump. **Always** disconnect power before repairing or servicing. **Never** apply electrical power to the system when any of the coverplates are removed.

⚠ CAUTION

Avoid prolonged skin contact with petroleum fuels. Use protective goggles, gloves and aprons in case of splashing or spills. Change saturated clothing and wash skin promptly with soap and water.

TROUBLESHOOTING

SYMPTOM	PROBABLE CAUSE	CORRECTIVE ACTION
A. MOTOR DOES NOT RUN	<ol style="list-style-type: none"> 1. Wiring problem 2. Fuse blown 3. Rotor or vanes jammed 4. Circuit breaker switch defective 5. Motor bad 	<p>Confirm all connections are tight and correct voltage is getting to the pump.</p> <p>Insert fuse in fuse holder on power cord. If blown, replace.</p> <p>Remove coverplate to expose rotor. Remove any obstructions. Check for excessive vane and slot wear. If damaged, replace.</p> <p>Replace switch</p> <p>Contact the factory.</p>
B. MOTOR RUNS, BUT NO FLOW	<ol style="list-style-type: none"> 1. Tank level low 2. Clogged filter assembly 3. Suction line problem 4. Broken motor shaft key 5. Bypass poppet stuck open 6. Motor running backwards 	<p>Add fuel to tank.</p> <p>Remove and clean filter assembly or replace.</p> <p>Remove suction pipe and remove any obstructions.</p> <p>Replace shaft key in end of shaft. Check slot and vane for excessive wear. Remove any obstructions.</p> <p>Remove bypass poppet and clean. If damaged, replace.</p> <p>Check wiring to confirm correct polarity.</p>
C. PUMP FAILS TO PRIME	<ol style="list-style-type: none"> 1. Air leak in system 2. Bypass poppet stuck open 3. Vanes worn or sticking 4. Motor runs backwards 	<p>Check for air leaks at all joints. Reseal and tighten.</p> <p>Remove bypass poppet and clean. If damaged, replace.</p> <p>Check slots and vanes for excessive wear or damage. If damaged, replace.</p> <p>Check wiring to confirm correct polarity.</p>

(continued on next page)

TROUBLESHOOTING

SYMPTOM	PROBABLE CAUSE	CORRECTIVE ACTION
D. LOW FLOWRATE	<ol style="list-style-type: none"> 1. Low voltage 2. Wiring problem 3. Clogged filter assembly 4. Air leak in system 5. Bypass poppet stuck open 6. Vanes worn or sticking 7. Outlet is blocked 8. Clogged or broken suction pipe 9. Fuel level low 10. Using off-the-shelf automatic nozzle 11. Hose damaged 	<p>Check battery voltage. Confirm voltage is correct.</p> <p>Confirm correct polarity and all connections are tight. Confirm wire size is correct and not too small.</p> <p>Remove and clean filter assembly or replace.</p> <p>Check for air leaks at all joints. Reseal and tighten.</p> <p>Remove bypass poppet and clean. If damaged, replace.</p> <p>Remove any obstructions. Check rotor slots and vanes for excessive wear. Replace if damaged.</p> <p>Check all accessories for blockage. Remove any obstructions.</p> <p>Remove pump and clear suction pipe, replace as needed.</p> <p>Fill tank.</p> <p>Factory-supplied automatic nozzle is recommended.</p> <p>Replace hose.</p>
E. MOTOR STALLS WHEN NOZZLE IS CLOSED	<ol style="list-style-type: none"> 1. Bypass poppet stuck closed 2. Rotor or vanes worn 3. Low voltage 4. Motor defective 	<p>Remove bypass poppet and clean or replace as needed.</p> <p>Check rotor and vanes for excessive wear. Replace as needed.</p> <p>Check incoming battery voltage and tighten wiring connections.</p> <p>UL Listing requires specific treatment for motor replacement, contact factory.</p>
F. FUEL LEAKAGE	<ol style="list-style-type: none"> 1. Threaded joints loose 2. Insufficient bolt torque 3. Lost or damaged O-rings 4. Shaft seal worn or damaged 5. Hose damaged 	<p>Check and reseal threaded joints.</p> <p>Retighten bolts.</p> <p>Check O-rings for damage. Replace as needed.</p> <p>Fuel leaking from drain hole indicates shaft seal needs to be replaced.</p> <p>Replace hose.</p>
G. MOTOR OVERHEATS	<ol style="list-style-type: none"> 1. Pumping high viscosity fluids 2. Clogged filter assembly 3. Clogged or broken suction pipe 4. Duty cycle too long 5. Motor failure 6. Bypass poppet clogged 	<p>Pump only low viscosity fluids.</p> <p>Clean filter assembly.</p> <p>Remove pump and clear suction pipe, replace as needed.</p> <p>Duty cycle is 30 minutes ON and 30 minutes OFF.</p> <p>Ball bearings damaged. UL Listing requires specific treatment for motor replacement, contact factory.</p> <p>Remove bypass poppet and clean.</p>

SPECIFICATIONS

	M-3025	M-3425
Application	Designed to safely transfer low viscosity petroleum fuels such as gasoline (up to 15% alcohol blends such as E15), diesel fuel (up to 20% biodiesel blends such as B20) and kerosene. Pump is designed for permanent mounting on vented storage tanks.	
Pump Housing	Cast Iron	
Performance:		
Pump Rate	Up to 25 GPM (94 LPM)	Up to 25 GPM (94 LPM)
Duty Cycle	30 min. ON, 30 min. OFF	30 min. ON, 30 min. OFF
Suction Lift:	Up to 15 feet (4.6 meters)	Up to 15 feet (4.6 meters)
Discharge Lift:	Up to 10 feet (3 meters)	Up to 10 feet (3 meters)
Operating Temperature	-20°F to +125°F (-29°C to +52°C)	
Electrical Specifications:		
Input	12-volt DC	24-volt DC
Current Draw	35 amps	20 amps
Motor	2000 RPM, 4/10 hp (300 watts)	2000 RPM, 4/10 hp (300 watts)
Motor Approval	cULus Listed. Class I, Division 1, Group D	cULus Listed. Class I, Division 1, Group D
Motor Protection	40 amp circuit breaker	20 amp circuit breaker
Cord	15 feet of 10 gauge (4.6 meters)	15 feet of 10 gauge (4.6 meters)
Fuse	40 amp	20 amp
Mechanical Connection:		
Bung	2 inch NPT	2 inch NPT
Inlet	1 inch NPT	1 inch NPT
Outlet	1 inch NPT	1 inch NPT
Accessories:		
Hose Type	Buna-N Electrically Conductive Discharge Hose	Buna-N Electrically Conductive Discharge Hose
Hose Size	1 NPT x 12 ft. (3.7 m)	1 NPT x 12 ft. (3.7 m)
Manual Nozzle	1 inch Leaded	1 inch Leaded
Automatic Nozzle	1 inch Diesel	1 inch Diesel
Weight:		
M-3X25-PO	51 lbs. (23 kg)	51 lbs. (23 kg)
M-3X25-ML	57 lbs. (26 kg)	57 lbs. (26 kg)
M-3X25-AL	60 lbs. (27 kg)	60 lbs. (27 kg)
M-3X25CS-PO	57 lbs. (26 kg)	57 lbs. (26 kg)
M-3X25CS-ML	71 lbs. (32 kg)	71 lbs. (32 kg)
M-3X25CS-AL	71 lbs. (32 kg)	71 lbs. (32 kg)

ILLUSTRATED PARTS DRAWING

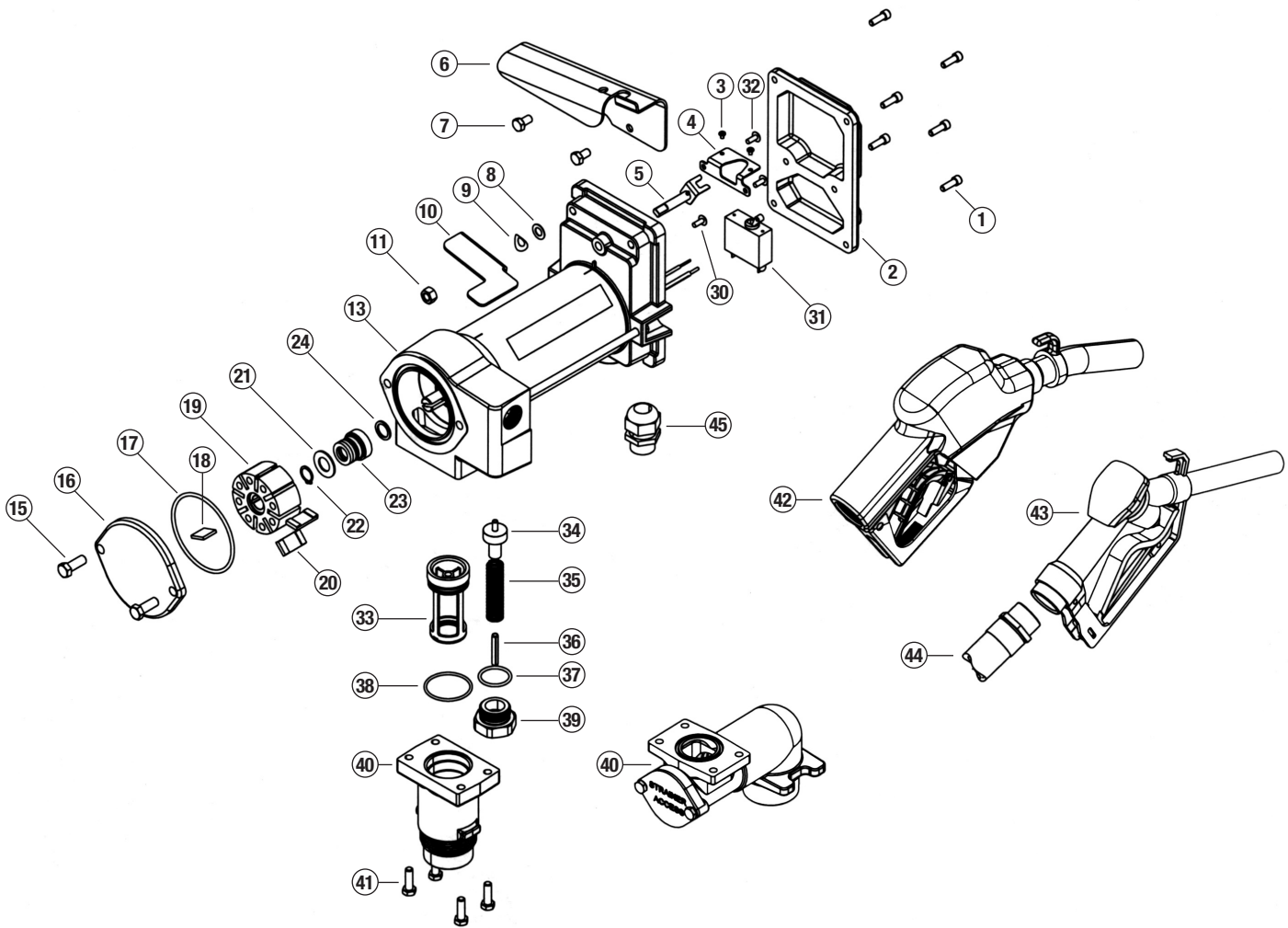

Item No.	Part No.	Description	No. Req'd.
1	904006-60	Screw - 1/4"-20 x 5/8"	6
2	133076-02	Conduit Box Cover	1
3	904005-56	Screw - #6-32 x 3/16"	2
4	133078-1	Switch Mounting Bracket	1
5	133086-1	Switch Actuator Assembly	1
6	13381101	Nozzle Cover	1
7	904004-59	Screw - 5/16"-18 x 9/16"	2
8	904006-16	Flat Washer	1
9	904006-63	Spring Washer	1
10	133081-1	Switch Lever	1
11	904006-62	Lock Nut - 3/8"-16	1
13	133508-01	Spare Motor, 12 VDC	1
	133508-02	Spare Motor, 24 VDC	1
15	904006-38	Screw - 3/8"-16 x 1"	2
16	133032-02	Coverplate	1
17	901003-15	O-Ring	1
18	121010-1	Motor Shaft Key	1
19	133022-1	Rotor	1
20	133020-1	Vane - Carbon	8
21	133027-1	Spacer Washer	1
22	904006-33	Retaining Ring	1

Item No.	Part No.	Description	No. Req'd.
23	906006-53	Shaft Seal	1
24	133026-1	Slinger Washer	1
30	904006-70	Ground Screw - #10-32 x 3/8"	1
31	902006-55	Switch/Motor Protector for 12 VDC motor	1
	902006-60	Switch/Motor Protector for 24 VDC motor	1
32	904002-25	Screw - #10-32 x 1/2"	2
33	133102-1	Filter Assembly	1
34	133505-01	Poppet Assembly Kit	1
35	133182-01	Poppet Spring	1
36	906004-50	Spring Pin	1
37	901002-50	O-Ring	1
38	901002-89	O-Ring	1
39	133059-02	By-pass Plug	1
40	133099-02	Inlet Base	1
	133052-01	Optional Spare Base Assembly	1
41	904004-37	Screw Hex Head 5/16"-18 x 1"	4
42	906005-1	Automatic Nozzle - Diesel	1
43	110155-4	Manual Nozzle - Leaded	1
44	110188-1	Hose Assembly - Fuel, 1 in. x 12 ft.	1
	133262-05	Hose Assembly, 1 in. x 20 ft.	1
45	902005-91	Strain Relief Sealing Grip	1

Items Not Shown

133093-1	Cord Assembly, 10/3 x 15 feet.
133501-1	Vane Kit includes vanes, key and O-ring.
133503-1	Shaft Seal Kit includes shaft seal, washer and retaining ring.
133504-1	Seal Kit includes all O-rings.
133509-02	Brush Kit (16-bar)

906001-4	Pressure Vent Cap (3 psi)
133532-02	40-Amp Fuse Kit (M-3025)
133532-01	20-Amp Fuse Kit (M-3425)

PARTS AND SERVICE

In order to preserve the UL Listing for the motor, do not attempt to service the motor. For products serviced outside the factory, the UL nameplate must be defaced to indicate that the equipment may no longer meet the requirements for UL Listing. This does not apply to products serviced outside the factory under the UL program for Rebuilt Motors for Use in Hazardous Locations.

For warranty consideration, parts, or other service information, please contact your local distributor. If you need further assistance, contact the GPI Customer Service Department in Wichita, Kansas, during normal business hours. A toll free number is provided for your convenience.

1-800-835-0113

To obtain prompt, efficient service, always be prepared with the following information:

1. The model number of your pump.
2. The serial number or manufacturing date code of your pump. For the M-3025 and M-3425 series pumps, the date code is located on the motor nameplate.
3. Part descriptions and numbers.

Part information can be obtained from the Illustrated Parts List.

For warranty work, always be prepared with your original sales slip or other evidence of purchase date.

Please contact GPI before returning any parts. It may be possible to diagnose the trouble and identify needed parts in a telephone call. GPI can also inform you of any special requirements you will need to follow for shipping fuel dispensing equipment.

CAUTION

Do not return the pump or parts without authority from the Customer Service Department. Due to strict government regulations, GPI cannot accept parts unless they have been drained and cleaned.

SAVE THESE INSTRUCTIONS

Limited Warranty Policy

Great Plains Industries, Inc. 5252 E. 36th Street North, Wichita, KS USA 67220-3205, hereby provides a limited warranty against defects in material and workmanship on all products manufactured by Great Plains Industries, Inc. This product includes a 2 year warranty. Manufacturer's sole obligation under the foregoing warranties will be limited to either, at Manufacturer's option, replacing or repairing defective Goods (subject to limitations hereinafter provided) or refunding the purchase price for such Goods theretofore paid by the Buyer, and Buyer's exclusive remedy for breach of any such warranties will be enforcement of such obligations of Manufacturer. The warranty shall extend to the purchaser of this product and to any person to whom such product is transferred during the warranty period.

The warranty period shall begin on the date of manufacture or on the date of purchase with an original sales receipt. This warranty shall not apply if:

- A. the product has been altered or modified outside the warrantor's duly appointed representative;
- B. the product has been subjected to neglect, misuse, abuse or damage or has been installed or operated other than in accordance with the manufacturer's operating instructions.

To make a claim against this warranty, contact the GPI Customer Service Department at 316-686-7361 or 800-835-0113. Or by mail at:

Great Plains Industries, Inc.
5252 E. 36th St. North
Wichita, KS, USA 67220-3205

The company shall, notify the customer to either send the product, transportation prepaid, to the company at its office in Wichita, Kansas, or to a duly authorized service center. The company shall perform all obligations imposed on it by the terms of this warranty within 60 days of receipt of the defective product.

GREAT PLAINS INDUSTRIES, INC., EXCLUDES LIABILITY UNDER THIS WARRANTY FOR DIRECT, INDIRECT, INCIDENTAL AND CONSEQUENTIAL DAMAGES INCURRED IN THE USE OR LOSS OF USE OF THE PRODUCT WARRANTED HEREUNDER.

The company herewith expressly disclaims any warranty of merchantability or fitness for any particular purpose other than for which it was designed.

This warranty gives you specific rights and you may also have other rights which vary from U.S. state to U.S. state.

Note: In compliance with MAGNUSON MOSS CONSUMER WARRANTY ACT – Part 702 (governs the resale availability of the warranty terms).



M-3025 and M-3425 Motor for
Hazardous Locations

GPI is a registered trademark of Great Plains Industries, Inc.
© 2008 by GREAT PLAINS INDUSTRIES, INC., Wichita, KS

Printed in U.S.A.



5252 East 36th Street North
Wichita, KS USA 67220-3205
TEL: 316-686-7361
FAX: 316-686-6746

GREAT PLAINS INDUSTRIES, INC.

"A Great Plains Ventures Subsidiary"

www.gpi.net

1-800-835-0113